

Chocolate surprise

With its sights set on an international reputation, Shenzhen's Club Chocolate has placed a high value on its audio system. Frank Shao reports

CALLED THE 'SHINJUKU' (TOKYO)

or 'Tsim Sha Tsui' (Hong Kong) of Shenzhen, Dong Men (Eastern Gateway) is one of the most popular shopping areas in the city. Offering everything from department stores and supermarkets to shops and stalls, it is centred around a large pedestrian area where most popular consumer brands can be found. The most recent pull the area has to offer is Club Chocolate – a nightclub providing a mixture of music club and traditional bar. The venue is pitched at high-income professionals, making the lighting and audio systems an essential consideration – along with the music that is the soul of the club.

Opened on 2 December 2007 at Dong Men, Club Chocolate is elegant and luxurious, using elaborate period-style flooring and lighting fittings as well as furniture and sculptures to create images of a European castle from the Middle Ages. Counterpointing the period theme, the club's technical installation involves some of the most current high-tech equipment including a Funktion-One loudspeaker system, a laser show and more than 20 computer-

controlled projectors. One of the club's 'signature' effects is the translucent bar tables that respond to any movement of objects above with corresponding changes in the projected images on the glass surface beneath. In the fast changing entertainment market, Chocolate Club has chosen its own distinctive character, with the aim of becoming not only one of the city's premier club venues but also establishing an international profile.

For its audio requirements, Club Chocolate's owners called on Hong Kong-based Hiroshi Systems to supply and design the whole system – and were presented with a proposal based around Funktion-One loudspeakers. Based in the UK but with a healthy profile in China, Funktion-One has set itself apart from the many manufacturers of line array loudspeaker systems, preferring point-source principles in its designs.

While the Chocolate Club has high expectations of its sound system, the irregular height and shape of the interior of the premises presented significant problems. These extended not only to acoustic performance but meant that there

was limited space for its installation. In addition, the loudspeakers were required not to interfere with other aspects of its operation, and would have to fit with the overall theme and décor. Regardless of the problems, the club's owners required that the sound pressure levels of the audio system to be high, and the sound quality good. These demands were met with confidence by the Hiroshi Systems designer Chan Yu Hing and his team, however, as the Funktion-One design philosophy lends itself well to this kind of installation and the company offers a variety of speakers in different sizes that work well together to provide a flexible and controlled distribution of sound.

In total, Club Chocolate occupies two floors, and a total area of 2,000-sq-m, with a capacity of 1,000, for whom 200 seats are available. In the centre of the first floor is the dancefloor, DJ booth and bar tables with booths on two sides. Since the shape of the venue is irregular, Hiroshi Systems determined that six Resolution 1 full-range speakers and two F221 high power 21-inch subwoofers directed towards the dancefloor should be installed in front of the DJ position. For other areas – such as the bar table and sofas – there are four Resolution 1 boxes, six F88s and eight F118 18-inch woofers. Inside each VIP room Hiroshi Systems installed a pair of F81 full-range loudspeakers, together with a Microbass 210 subwoofer, while the DJ booth uses a pair of RM15 monitor speakers.

The second floor contains the VIP area – a 700-sq-m reserve allowing elite customers to watch the action on the dancefloor and in the DJ



Club Chocolate entrance



The VIP view of the DJ area

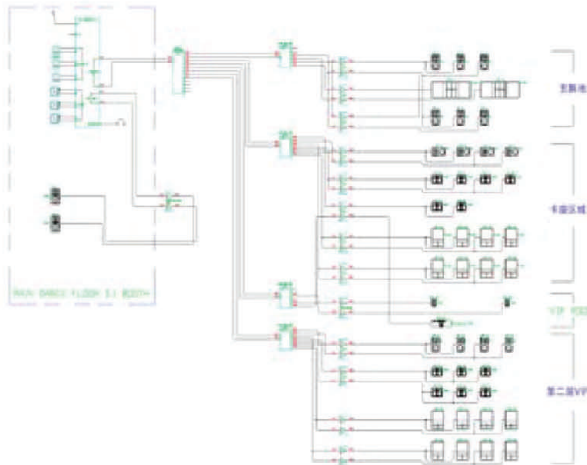

Chocolate sound system schematic



RM15 speakers in the DJ booth

booth. In this area, a further four Resolution 1 cabinets, six F88s and eight F118s have been installed. With this flexible design, the same level of high-quality music can be maintained in every corner of the club.

On 2 December 2007, Club Chocolate held a dry run in advance of its official launch, covering all aspects of the club's operation and staffing. It fell to DJ Eddie to play and mix different styles of music while house dancers performed on small stages and the lighting staff ran their show. With the rehearsal completed smoothly, both the owner and DJ were happy with the performance of the Funktion-One system. 'I think even four or 18-inch woofers from other brands would not perform as well as a pair of Funktion-One F221 subwoofers,' DJ Eddie commented.

Chocolate formally opened its doors on 3 December, with the queue of enthusiastic customers that had formed eagerly at the entrance quickly filling out all the different function areas. The music kicked off at 8pm together with a spectacular laser show, while the bartenders kept up a cocktail mixing display of their own. The lasers tracked the changing musical styles played by the DJ, bringing the club's punters onto the dancefloor and even into the open areas surrounding it. Some of them used the F221 subs as personal dance spaces, while the house dancers performed on their stages, leading the partygoers on the dancefloor.

The intended success of the Chocolate Club was boosted by a full house of customers on its opening night, all of which seemed to fully enjoy their time inside the club. If this success can be maintained, Club Chocolate and Hiroshi Systems can be hopeful that their ambition to establish a new benchmark high-end audio system on China's club scene is safely on track.

Hiroshi Systems, Hong Kong:
+85 2 2330 5683
www.hiroshi.com.hk
www.funktion-one.com